



VOLAIR SIM UNIVERSAL FLIGHT | RACING SIM CHASSIS

P/N: VS-01-2B

ASSEMBLY INSTRUCTIONS

Rev. 1.71

Thank you for purchasing the Volair Sim™ Universal Flight | Racing Sim Chassis! We hope that it will give you countless hours of enjoyment. Although we have designed the system with ease of assembly in-mind, please read these instructions carefully first.

NOTE: SOME OF THE PARTS MAY VARY FROM THOSE SHOWN IN THE PHOTOS BELOW AS WE CONTINUOUSLY IMPROVE OUR PRODUCTS. SOME FASTENERS MAY BE PRE-INSTALLED ON THE CHASSIS.

PLEASE VISIT OUR WEBSITE AND YOUTUBE CHANNEL FOR ADDITIONAL INSTRUCTIONS AND TIPS.

THIS MANUAL IS AVAILABLE IN PDF VERSION FROM THE SUPPORT SECTION OF OUR WEB-SITE.

We recommend that you find an open space to carefully unpack and inventory all of the components and mounting hardware before beginning the assembly process. Please refer to the **INSTALLATION DRAWING** to verify that you have all of the chassis components and **TABLE 1** below for all of the mounting hardware. Throughout the assembly process, please refer to **TABLE 1** which references the parts used during each step of the assembly. You should note that all hardware is metric. Although we provided you with basic tools, we recommend that you also use an adjustable wrench, Philips screwdriver, and a metric socket set during installation.





NO.	PART NAME	QTY	PHOTO	NO.	PART NAME	QTY	PHOTO
1	M6*25mm Button Head Machine Screw	4 (all are pre-installed)		11	M8*20mm Socket Cap Machine Screw	4	
2	M6*30mm Button Head Machine Screw	5 (3 are pre-installed)		12	M8 Self-Locking Nut	1	
3	M8*16mm Socket Cap Machine Screw	4		13	Nylon Washer	1	
4	M6 Self-Locking Nut	8 (2 are pre-installed)		14	Hex Key M4	1	
5	M8*20mm Machine Screw with Knob	12		15	Hex Key M6	1	
6	M8*35mm Socket Cap Machine Screw	12		16	Universal Wrench	1	
7	M8*20mm Machine Screw with Knob	10		17	Silicon Grease	1 bag	
8	M8 Flange Nut	12		18	Seat Spacer	4	
9	M6*35mm Button Head Machine Screw	4		19	Velcro Strip	2	
10	M4*12mm Phillips Machine Screw and M4 Washer	12		20	M8 Washer	4	

TABLE 1: HARDWARE LIST

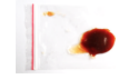

INSTALLATION DRAWING

STEP 1: ATTACHING MONITOR BASE TO SEAT BASE

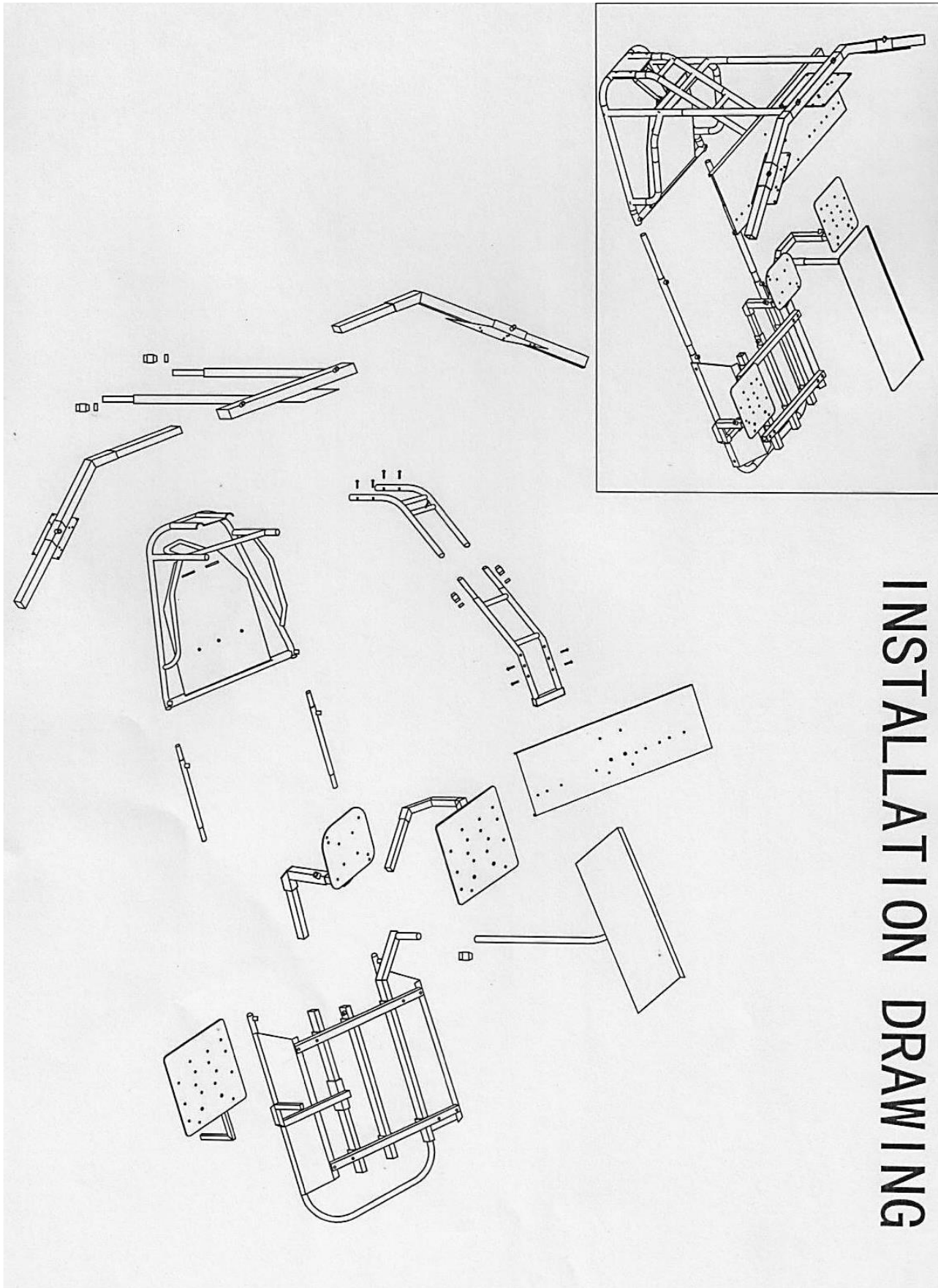
Begin assembly by attaching the monitor base to the seat base using the adjustment tubular connectors as shown in **FIGURE 1** below. The inner adjustment tubes allow you to vary the distance between the seat base and the monitor base. Use four (4) M8*20mm Socket Cap Machine Screws (No. 3) and two (2) M8x20mm Machine Screws with Knob (No. 5). You can adjust the optimum seat distance later.

TIP: APPLYING A THIN LAYER OF SILICON GREASE (NO. 17) ONTO THE INNER ADJUSTMENT TUBES WILL FACILITATE INSTALLATION AND FURTHER ADJUSTMENTS

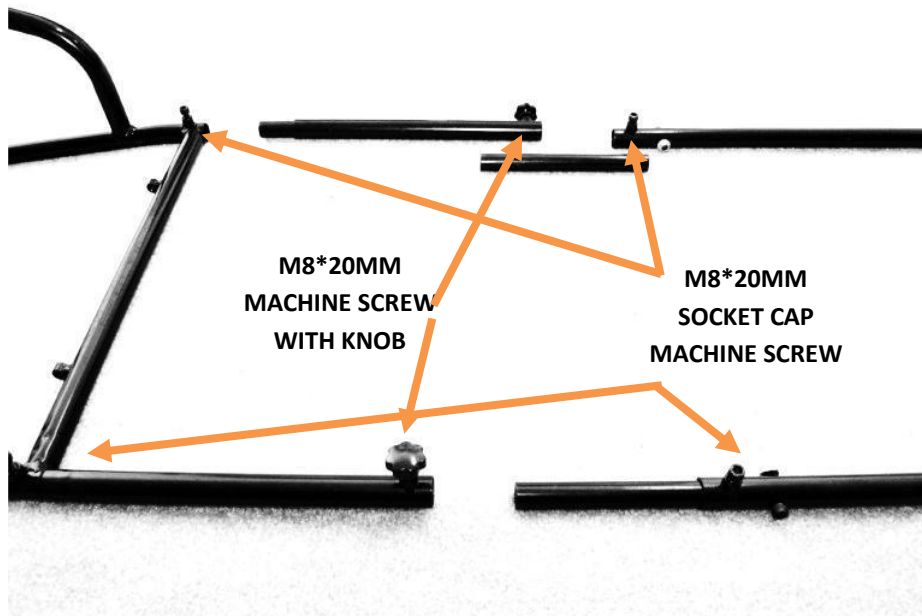

FIGURE 1: ATTACHING MONITOR BASE TO SEAT BASE

STEP 2: PEDAL TRAY

Flip the monitor base and seat base over and attach the pedal tray using two (2) M6*30mm Button Head Machine Screws (No. 2) and two (2) M6 Self-Locking Nuts (No. 4) (these may be pre-installed). See **FIGURES 2A** and **2B** below:



FIGURE 2A: ATTACHING PEDAL TRAY TO MONITOR BASE

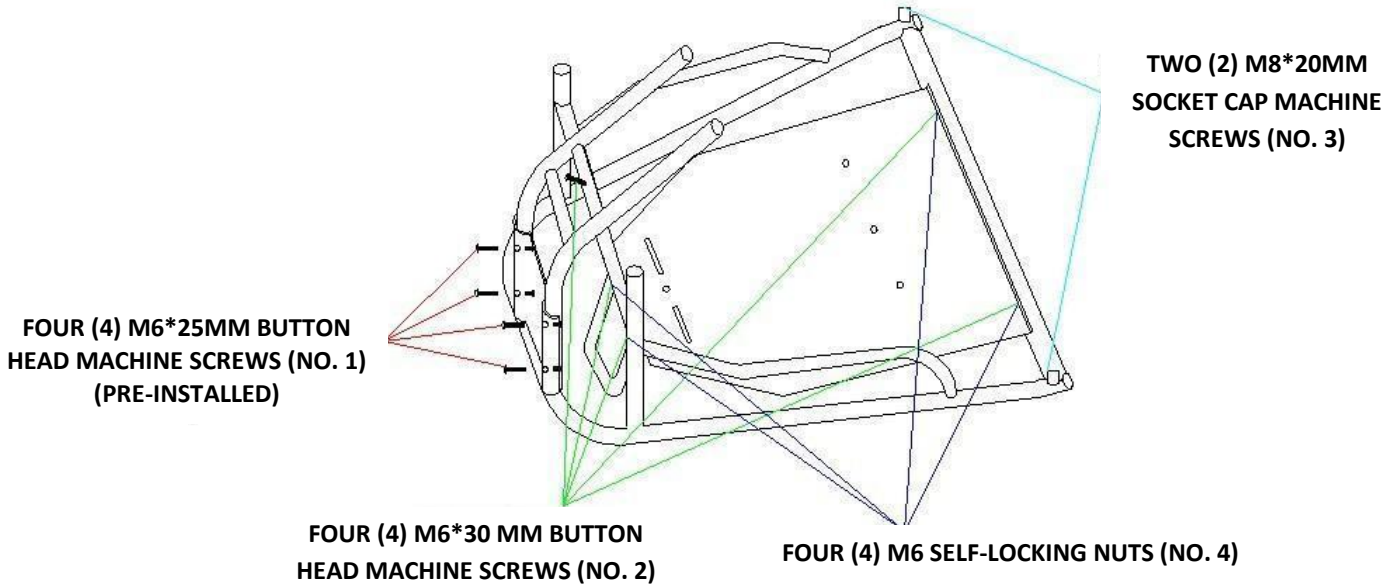

FIGURE 2B: MONITOR SUPPORT BASE WITH PEDAL TRAY

STEP 3: CENTER MONITOR SUPPORT

Attach center monitor support to monitor base as shown in **FIGURE 3**. Do not tighten the plastic adjustment nuts (circled below) all the way at this time since you will want to adjust the height after installation of monitors.



FIGURE 3: ATTACHING CENTER MONITOR SUPPORT TO MONITOR BASE

STEP 4: AVIONICS | WORK TABLE

Attach the avionics table to the support structure with four (4) M6*35mm Button Head Machine Screws (No. 9) and four (4) M6 Self-Locking Nuts (No. 4). Note that there are two positions (as shown in **FIGURE 4**) in which the table can be mounted depending on whether you want the table closer or farther away from you. Ensure that the row of holes drilled along the top edge of the table is facing towards the seat. These holes are pre-drilled for attaching the Volair Sim Avionics Panel, Logitech (Saitek) Pro Flight Yoke, Logitech Steering Wheel, Thrustmaster T500RS Steering Wheel, and Logitech (Saitek) Pro Flight Accessories (on left and right sides of the yoke) to table.

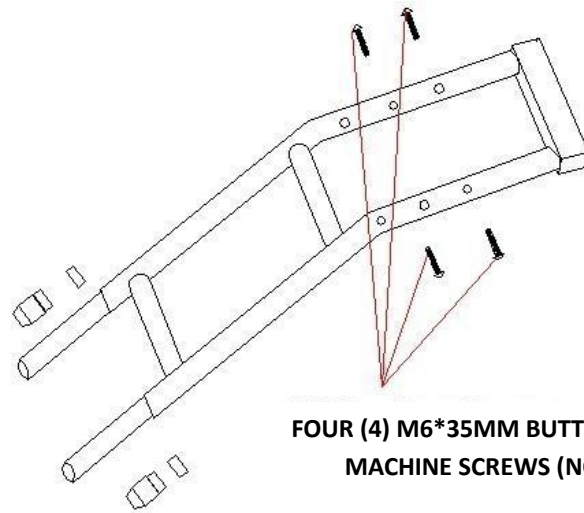

FOUR (4) M6*35MM BUTTON HEAD
MACHINE SCREWS (NO. 9)

FOUR (4) M6 SELF-LOCKING NUTS (NO. 4)

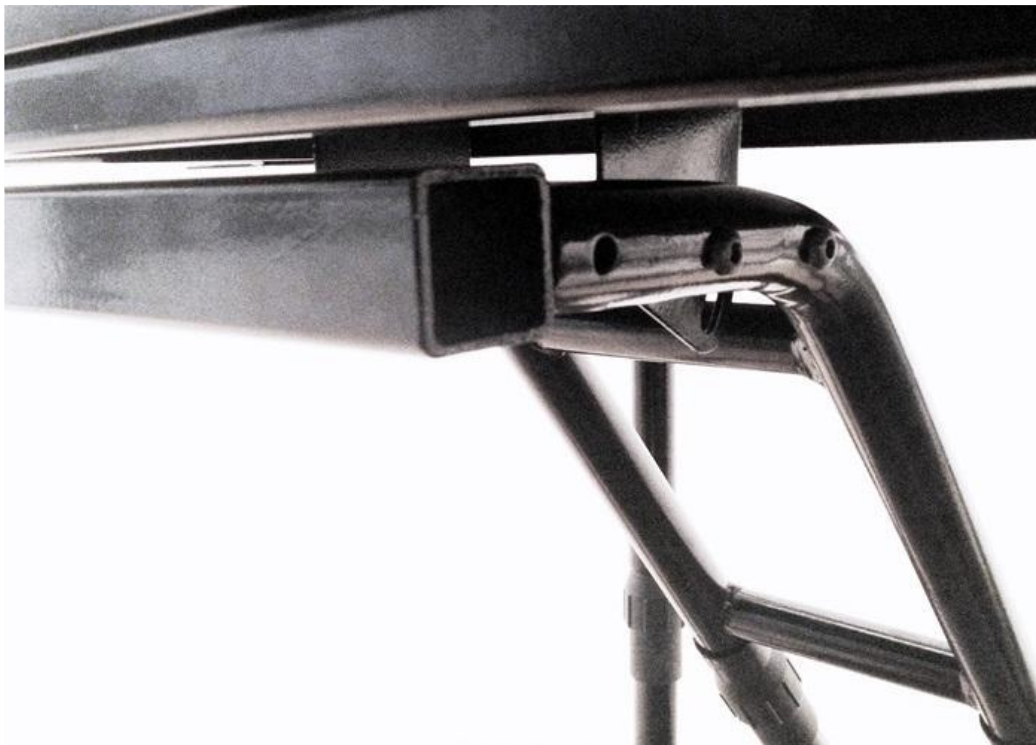

FIGURE 4: ATTACHING TABLE TO SUPPORT STRUCTURE

STEP 5: ATTACHING AVIONICS | WORK TABLE TO MONITOR BASE

Attach the assembled table and support structure to the monitor base and tighten the plastic adjustment plastic nuts (circled) lightly as shown in **FIGURE 5**. You will be able to adjust the distance and angle of the table to suit your preferences after the entire assembly process is complete.



FIGURE 5: ATTACHING THE AVIONICS TABLE TO MONITOR BASE

STEP 6: SEAT RISER ASSEMBLY

Attach seat risers to the seat base using four (4) M8*35mm Socket Cap Machine Screws (No. 6) and four (4) M8 Flange Nuts (No. 8) as shown in **FIGURE 6** below.



FIGURE 6: ATTACHING SEAT RISERS TO SEAT BASE

STEP 7: SEAT SUPPORT ASSEMBLY

Continue the assembly of the seat base as shown in **FIGURE 7** with the two cross braces (#1) and the left (#2), center (#3) and right (#4) square tubes. **Note that the seat support brackets attach to the OUTERMOST holes on the two cross braces and that the open square profiles on the cross braces point towards the floor.** You may need to apply some pressure and bend the seat risers outward as you insert the four (4) M8*35mm Socket Cap Machine Screws through the cross braces. Partially thread the Machine Screws with Knobs into the open square channels under cross braces which will later be used to secure the left, center, and right mounts.

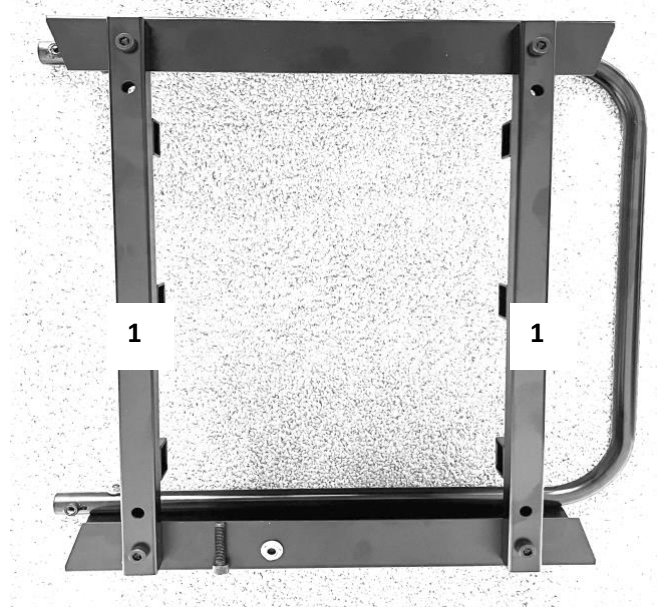

SEVEN (7) M8*20MM MACHINE
SCREWS WITH KNOBS (NO. 5)

RIGHT (8) M8 FLANGE
NUTS (NO. 8)

EIGHT (8) M8*35MM
SOCKET CAP MACHINE
SCREWS (NO. 6)

TWO (2) M8*20MM
SOCKET CAP MACHINE
SCREWS (NO. 3)

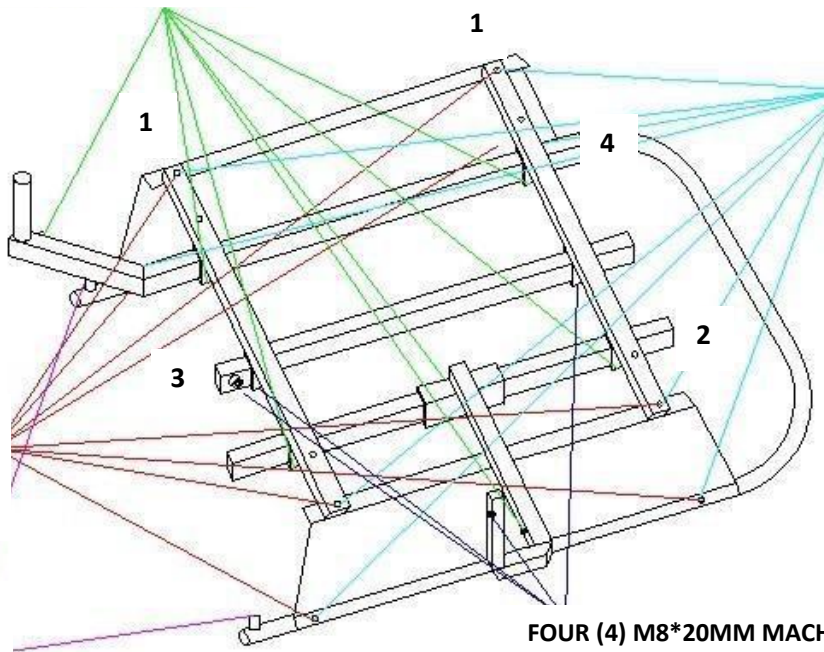

FOUR (4) M8*20MM MACHINE
SCREWS WITH KNOBS (NO. 7)

FIGURE 7: SEAT SUPPORT ASSEMBLY

STEP 8: SEAT ASSEMBLY

Attach the two seat sliders to the seat base using four (4) M8*35mm Socket Cap Machine Screws (No. 6), and four (4) M8 Flange Nuts (No. 8) as shown in **FIGURE 8A**. Remember to place four (4) M8 silver-colored washers (No. 20) between the bottom of sliders and top of the seat support brackets. This will ensure that the left and the right-side mounts have adequate clearance for forward and aft movement. **HINT: You can move the sliders to forward/aft position to provide access to slider mounting holes. Note the adjustment slider handle location and lift the handle UP to allow movement.**

Next, attach the seat to the two sliders as shown in **FIGURE 8B** taking care that you place the four (4) dish-shaped Seat Spacers (No. 18) between the sliders and the seat as shown in **FIGURE 8C**.

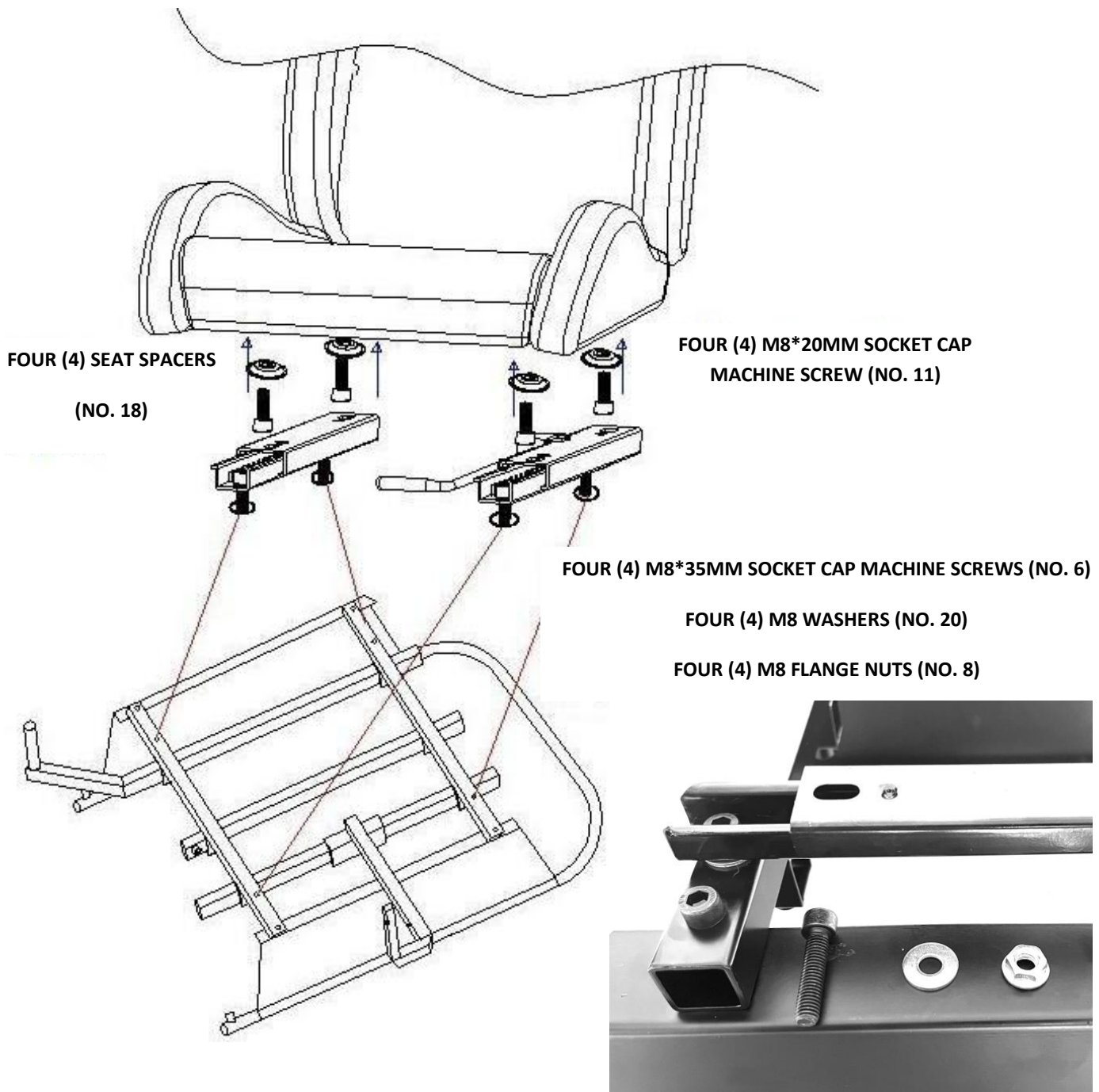

FIGURE 8A: ATTACHING THE SEAT SLIDERS TO SEAT BASE

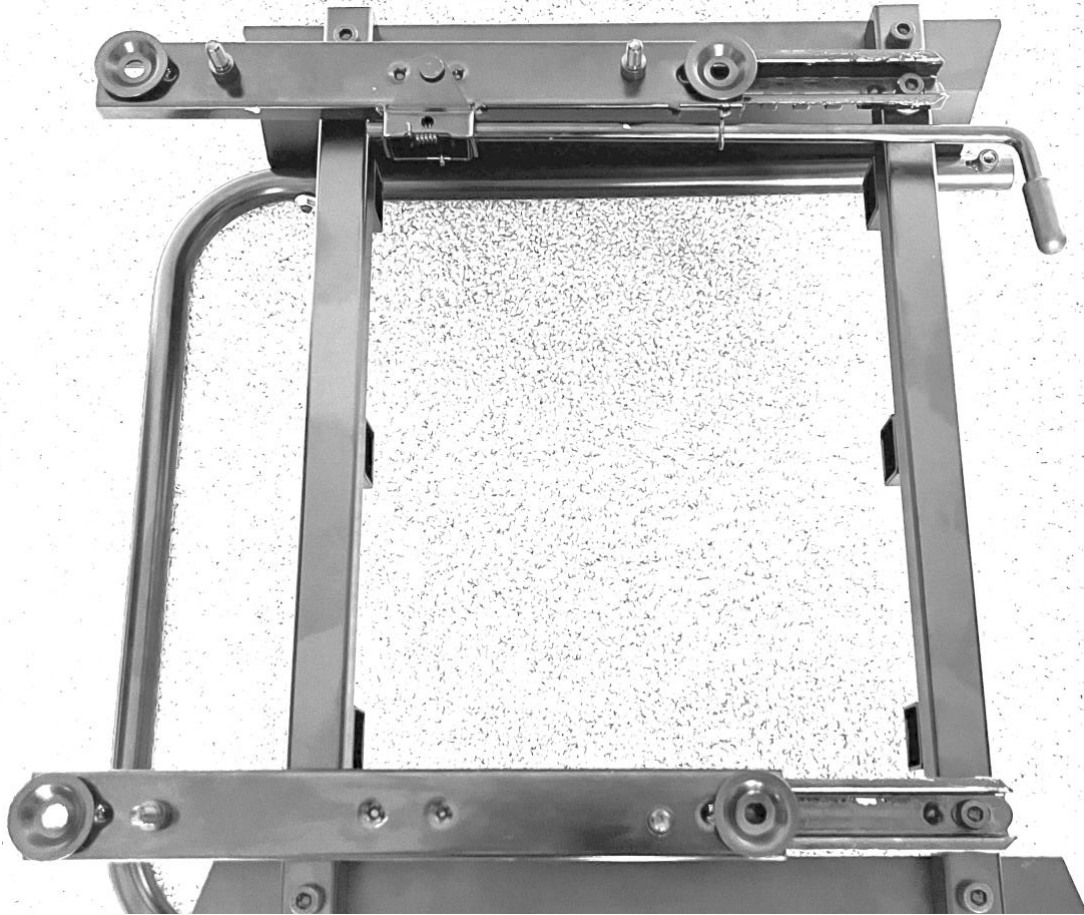

FIGURE 8B: ATTACHING THE SEAT TO SEAT SLIDERS

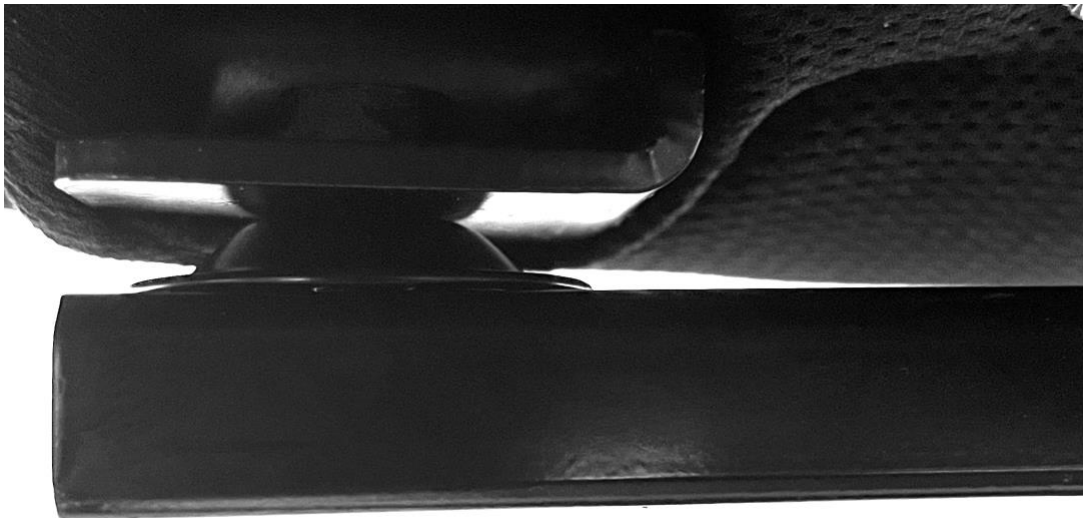

FIGURE 8C: SEAT SPACER (NO. 18) POSITIONING BETWEEN THE SEAT AND SEAT SLIDER

STEP 9: SIDE AND CENTER MOUNT ASSEMBLY

Assemble the left and right side-mounts as shown in **FIGURE 9A** below. Use M8*20mm Machine Screws with Knobs (No. 5) to tighten the support plates to the L-shaped supports. Next, assemble the center stick mount per **FIGURE 9C**. Use **FIGURE 9D** to visualize the completed orientation of the left, center, and right mounts.

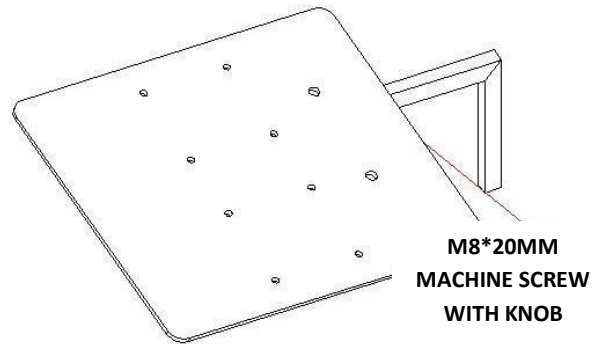

FIGURE 9A: LEFT-HAND MOUNT

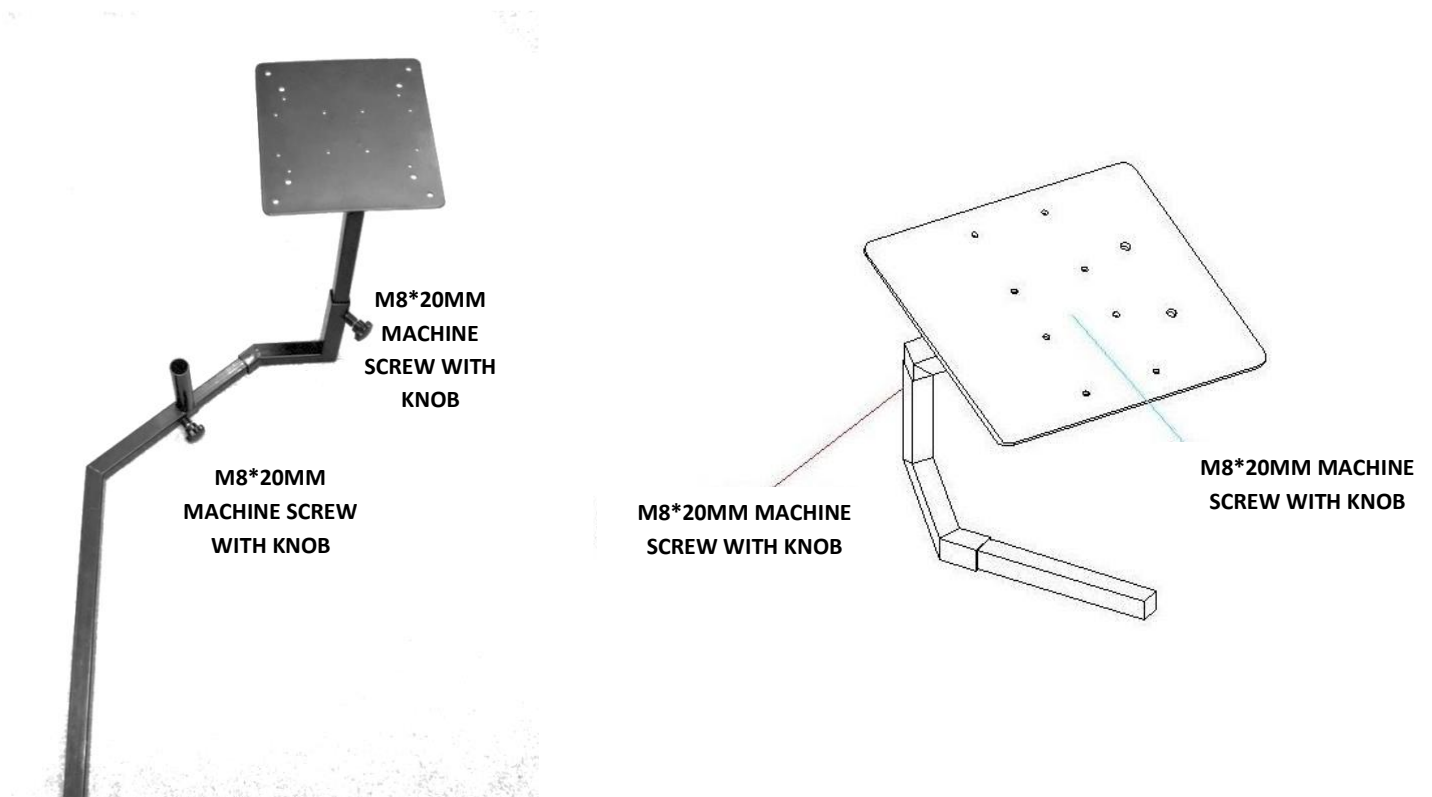

FIGURE 9B: RIGHT-HAND MOUNT

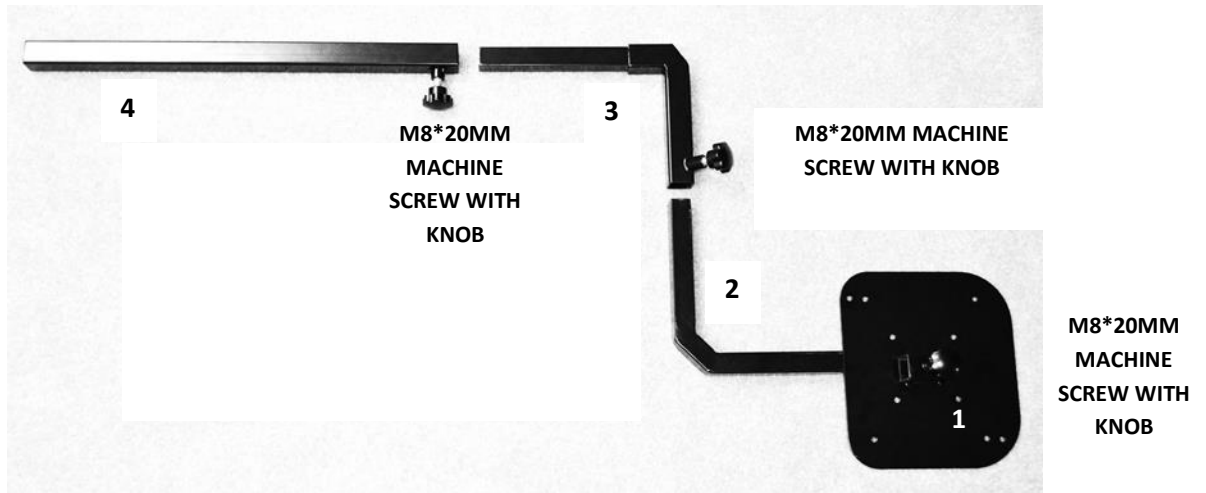

FIGURE 9C: CENTER MOUNT

1. Joystick mounting plate with M8*20mm Machine Screw with Knob
2. Right angle support tube
3. Vertical tube with M8*20mm Machine Screw with Knob
4. Center tube with M8*20mm Machine Screw with Knob

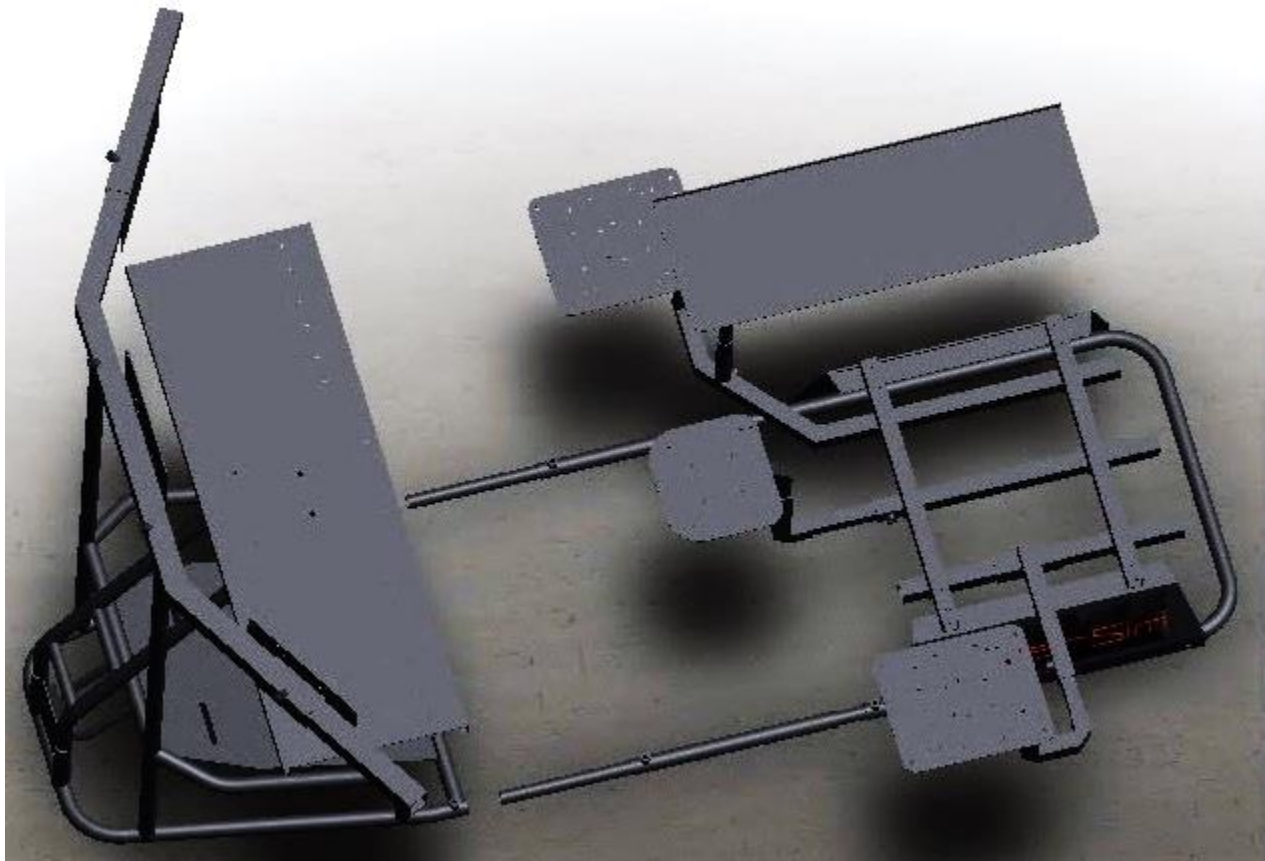

FIGURE 9D: COMPLETED MOUNT ASSEMBLY

STEP 10: SIDE MONITOR ASSEMBLY

Assemble the side monitor mounts as shown in **FIGURE 10**. Use the provided M4*12mm Phillips Machine Screws and M4 Washers (No. 10) or suitable machine screws as needed (your display may require larger or longer screws than provided). The Volair Sim cockpit mounts are pre-drilled with the industry standard VESA bolt patterns for most of the common monitor bolt pattern sizes (see below).

In order to get the alignment of the side displays with the center one, first loosen all of the adjustment screws on the monitor arms, monitor brackets, and on the back of the monitor (VESA). Note that in order to get the proper alignment of the side bezels you can move the side monitors on their arms and also slide the monitor left and right arms in and out of the center support. Also, note that the holes on the left and right monitor brackets are slotted so you can rotate the monitors slightly and also move them up/down.

Next, ask a helper to hold the left monitor in perfect position with the center monitor. When satisfied with the position, tighten all of the screws while the helper is holding the monitor in position until you are finished. Next, repeat the process for the right monitor taking care that the angle and bezel spacing of the right monitor is the same as the left one. **Again, remember you can achieve the right angle and bezel position by independently moving the arm in/out of the center support and also sliding the monitor left and right on the arm.**

With a little time and patience, a seamless positioning can be achieved where the displays are aligned well with the center one and the bezel spacing is minimized and uniform across all three displays.

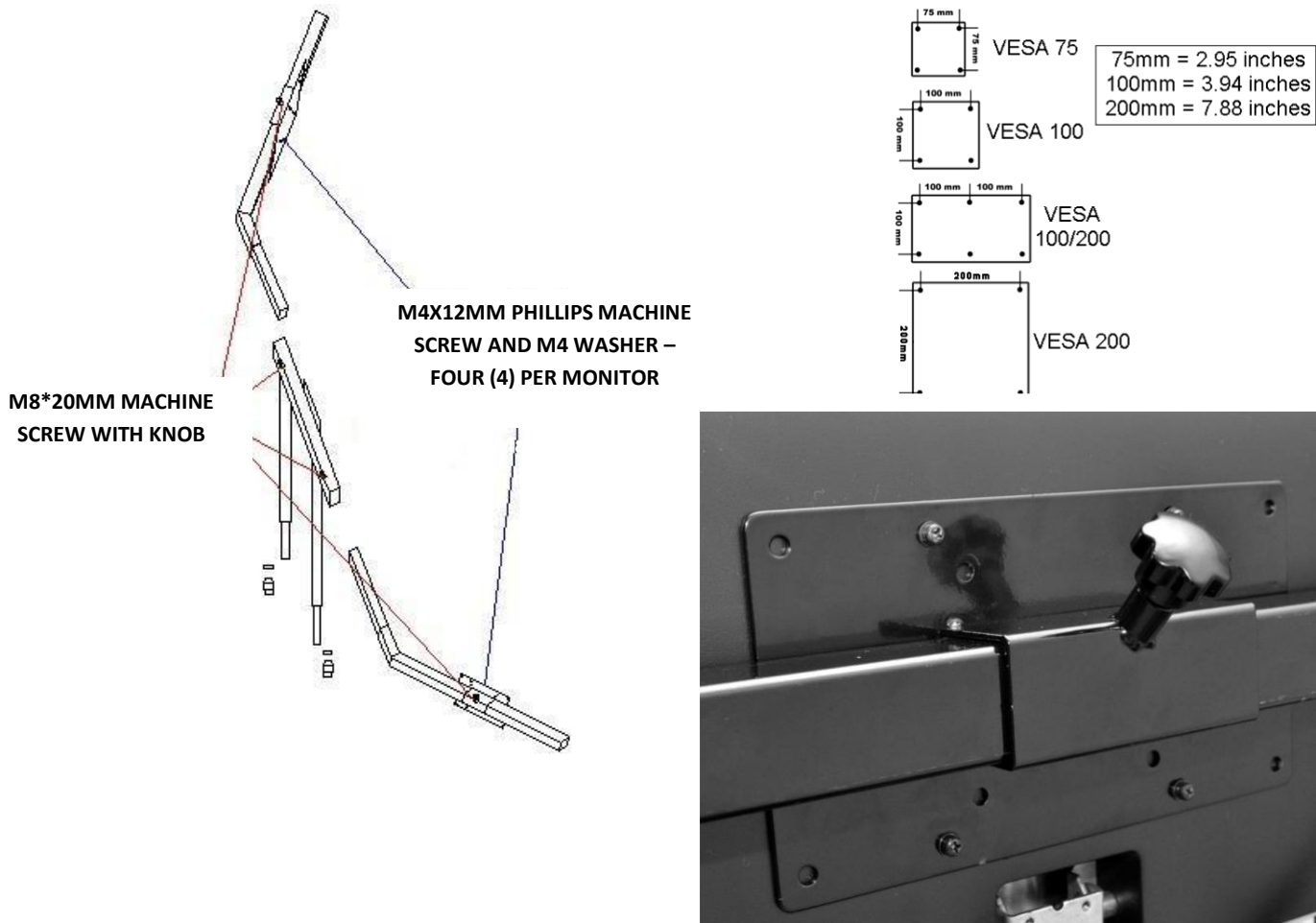

FIGURE 10: SIDE MONITOR MOUNT BRACKET

STEP 11: KEYBOARD TRAY ASSEMBLY

Attach keyboard tray to the keyboard support structure as shown in **FIGURE 11**. First, apply some of the enclosed silicon grease between the two sliding parts of the keyboard tray and the keyboard post. Next, place the keyboard on the keyboard support post. Insert the white Nylon Washer (No. 13) immediately **underneath** the M8 Self-Locking Nut (No. 12) and tighten until it is snug. Do not over-tighten the locknut as you will not be able to rotate the keyboard tray freely. Use the plastic adjustment nut to adjust the height of the keyboard and tighten to lock in-place.

HINT: IF YOUR KEYBOARD TRAY WOBBLER AFTER ASSEMBLY, ENSURE THAT YOU ACCIDENTALLY DID NOT POSITION THE NYLON NUT BETWEEN THE POST AND TRAY.

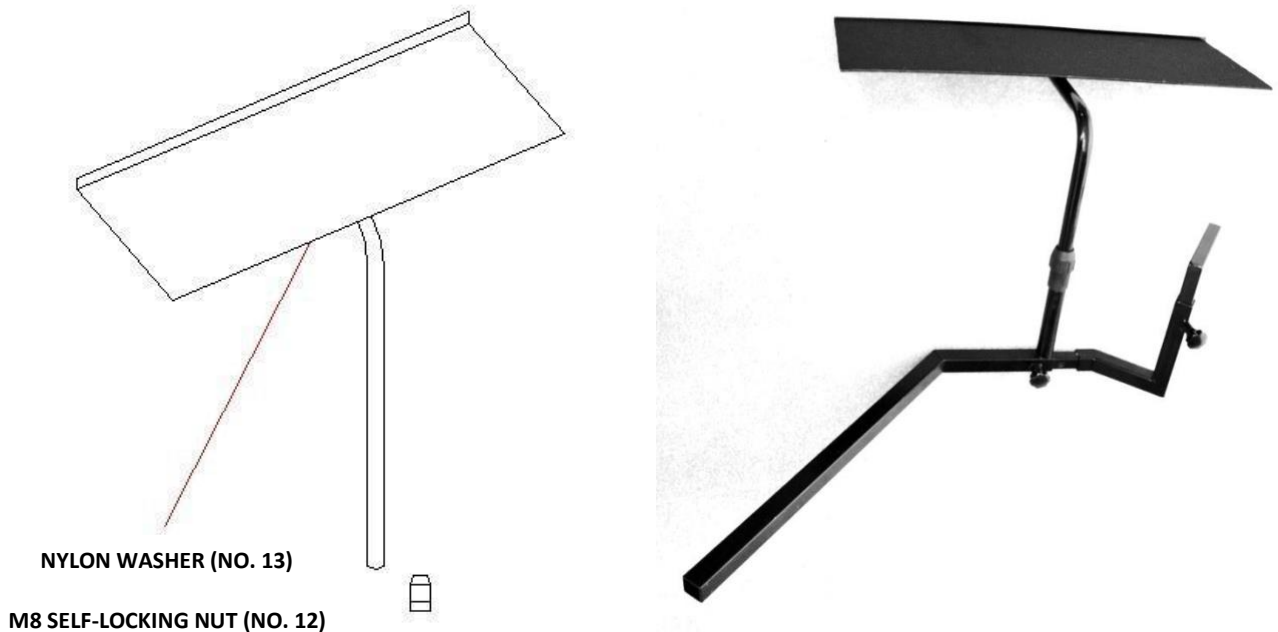

FIGURE 11: KEYBOARD TRAY ASSEMBLY

STEP 12: ATTACHING ACCESSORIES

You have several options when attaching accessories to the Volair Sim chassis. You can opt for a permanent installation using the pre-drilled locations or a semi-permanent installation using the clamps provided with the yoke, steering wheel, and associated accessories.

1. Yoke | Steering Wheel Installation

The Volair Sim cockpit chassis is pre-drilled to accept the Logitech (Saitek) Pro Flight Yoke, Logitech G27|G29, and Thrustmaster T500RS steering wheels. Use the fasteners provided with your accessories to attach the steering wheel and yoke to the table. Note that in order to mount the Logitech steering wheel, shifter, and pedals using the pre-drilled locations, you will need eight (8) M6*10mm machine screws (2 for the wheel, 2 for the shifter, and 4 for the pedals). You can purchase these at any hardware store. Note: The Honeycomb Alpha yoke can be attached with the micro-suction pad mount (included with the yoke) or the clamping system. The Honeycomb yoke does not have any provision for installation with screws.

2. Throttle Quadrant | Trim Wheel | Gear Shifters | HOTAS systems

Volair Sim features pre-drilled locations for the Saitek Throttle Quadrant(s), Thrustmaster HOTAS Warthog, Logitech (Saitek) X-52|X-55|X-56, Fanatec ClubSport Shifter SQ. You can also combine several Logitech quadrants for a twin or multi-engine set-up, set-up HOTAS systems, or gear shifters for either left or right-hand drive. The Honeycomb Bravo can be installed with either the micro-suction pad mount (included with the throttle quadrant) or dual-sided 3M tape (sold separately). The Bravo throttle does not have provisions for installation with screws.

NOTE: for the Thrustmaster HOTAS Warthog installation, the throttle plate will overlap the mounting plate on top and bottom. You should use the bottom two holes pre-drilled in the side mount plate for attachment. Also, in order to use the center mount for Thrustmaster HOTAS installation, you will have to remove the Thrustmaster joystick from the large support plate included with the HOTAS system and mount it directly on Volair Sim center support plate using pre-drilled holes.

3. Rudder Pedals | Racing Pedals

The pedal base accepts a wide variety of rudder pedals such as: CH Products Pro Pedals, Thrustmaster, and Logitech, Yoko, and others. The pedal base has pre-drilled holes for the Logitech G27|G29, Fanatec Clubsport, and Thrustmaster T500RS pedals, but you can mount nearly any rudder and racing pedals with the provided Velcro strips. Just attach one strip to the bottom of the pedal base and the second strip to the pedals or rudder set and you will have a very secure installation.

4. Flight Simulation Accessories

For flight simulation, Volair Sim has pre-drilled mounting locations for all Logitech Pro Flight accessories including the Radio Panel, the Multi Panel, Switch Panel, and the Flight Instrument Panel(s). Just use the machine screws provided with the Logitech accessories and attach the accessories on either left or right side of the yoke as desired. Note that you will be able to mount the Volair Sim Avionics Panel (sold separately) for even greater realism. Honeycomb products, due to the fact that they do not have provisions for screw-down installation, are best installed using either the micro-suction system included with the Honeycomb yoke and throttle quadrant or couple of strips of dual-sided 3M tape.

5. Additional Volair Sim Accessories

Volair Sim offers several accessories (sold separately) for your Volair Sim cockpit. The armrests attach to your Volair Sim cockpit allowing greater precision and comfort, especially when flying with the side stick or a HOTAS system. The Volair Sim Avionics Panel (available in “steam gauge” or “glass cockpit” G1000 variants) allows you to create a realistic aircraft avionics panel complete with a padded carbon-fiber-look glare shield for ultimate flight realism. The optional triple display stand allows you to mount up-to three (3) 50” large displays. Please visit www.volairsim.com for more details. Enjoy your Volair Sim!



VOLAIR SIM CHASSIS WITH THE OPTIONAL TRIPLE DISPLAY STAND AND THE VOLAIR SIM G1000 AVIONICS PANEL